

MDFL 1510/1880/2505/ 2705 DUAL FUEL BURNER

441 – 2705 kW



- Designed and approved in accordance with the European Standard EN 267 and EN 676
- 2 stage or modulating gas / 2 stage oil
- Plug-in contact facilitates the installation
- Available for natural gas, LPG, town gas, biogas
- Light oil
- Hinged flanged

NU-WAY

Type		MDFL 1510	MDFL 1880	MDFL 2505	MDFL 2705
Capacity	kW	441-1510	738-1880	620-2505	887-2705
Motor	V/Hz kW/A (Fuse) + Control fuse	400 / 50 3.0 / 3 x 20 + 1 x 10	400 / 50 4.0 / 3 x 20 + 1 x 10	400 / 50 4.4 / 3 x 20 + 1 x 10	400 / 50 5.5 / 3 x 20 + 1 x 10
Start/Run Current	Amps	10.5/6.5	15.0/9.0	15.5/9.3	16.3/11.3
Control unit		MPA 22	MPA 22	MPA 22	MPA 22
Flame monitoring		UV	UV	UV	UV
Air damper motor		•	•	•	•
Gross weight	kg				
Volume	m ³				

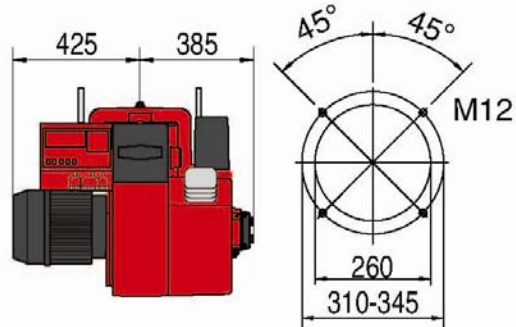
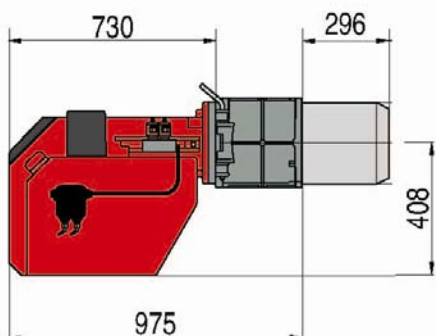
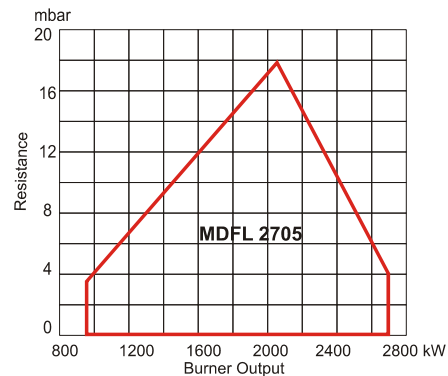
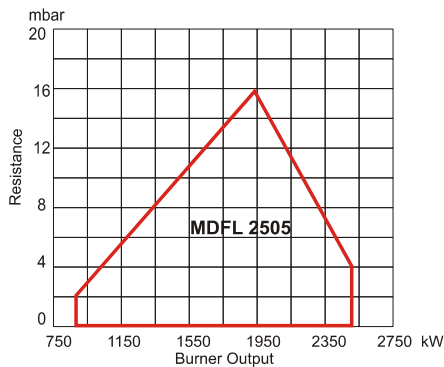
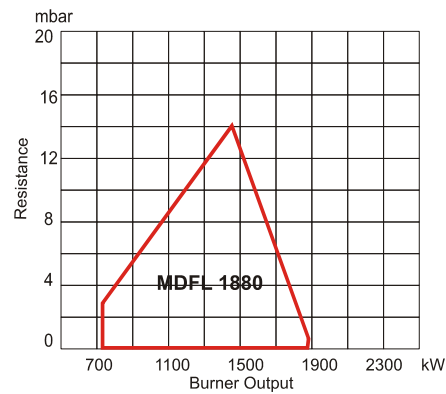
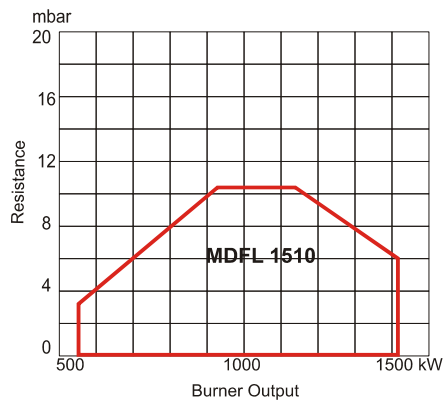

* Extended Lengths Available

NU-WAY

Nu-way Limited
P O Box 1, Vines Lane
Droitwich
Worcestershire
WR9 8NA

tel: +44 (0) 1905 794331
fax: +44 (0) 1905 794017

email: info@nu-way.co.uk
web: www.nu-way.co.uk