

# MDFL 2800-38 & 2800-41 DUAL FUEL BURNER

774 - 2730 kW



- Designed and approved in accordance with the European Standard EN 267 and EN 676
- 2 stage or modulating gas/2 stage oil operation
- Plug-in contact facilitates the installation
- Available for natural gas, LPG, town gas, biogas
- Light or heavy oil
- Hinged flange

**NU-WAY**

Type		MDFL 2800-38	MDFL 2800-41
Capacity		774 – 2730	774 - 2730
Motor	V/Hz	400/50	400/50
	kW/A (Fuse)	7.5/3 x 32 HRC	7.5/3 x 32 HRC
Start/Run Current	Amps	88.9 / 15.2	97.0 / 25.3
Operation		2-stage – Oil & Gas	2-stage – Oil & Gas
Control unit		Landis	Landis
Max inlet pressure		300	300
Flame monitoring		UV Cell	UV Cell
Air damper motor		Landis	Landis
Leakage control		•	•
Gross weight		300	300
Volume		2.005	2.005

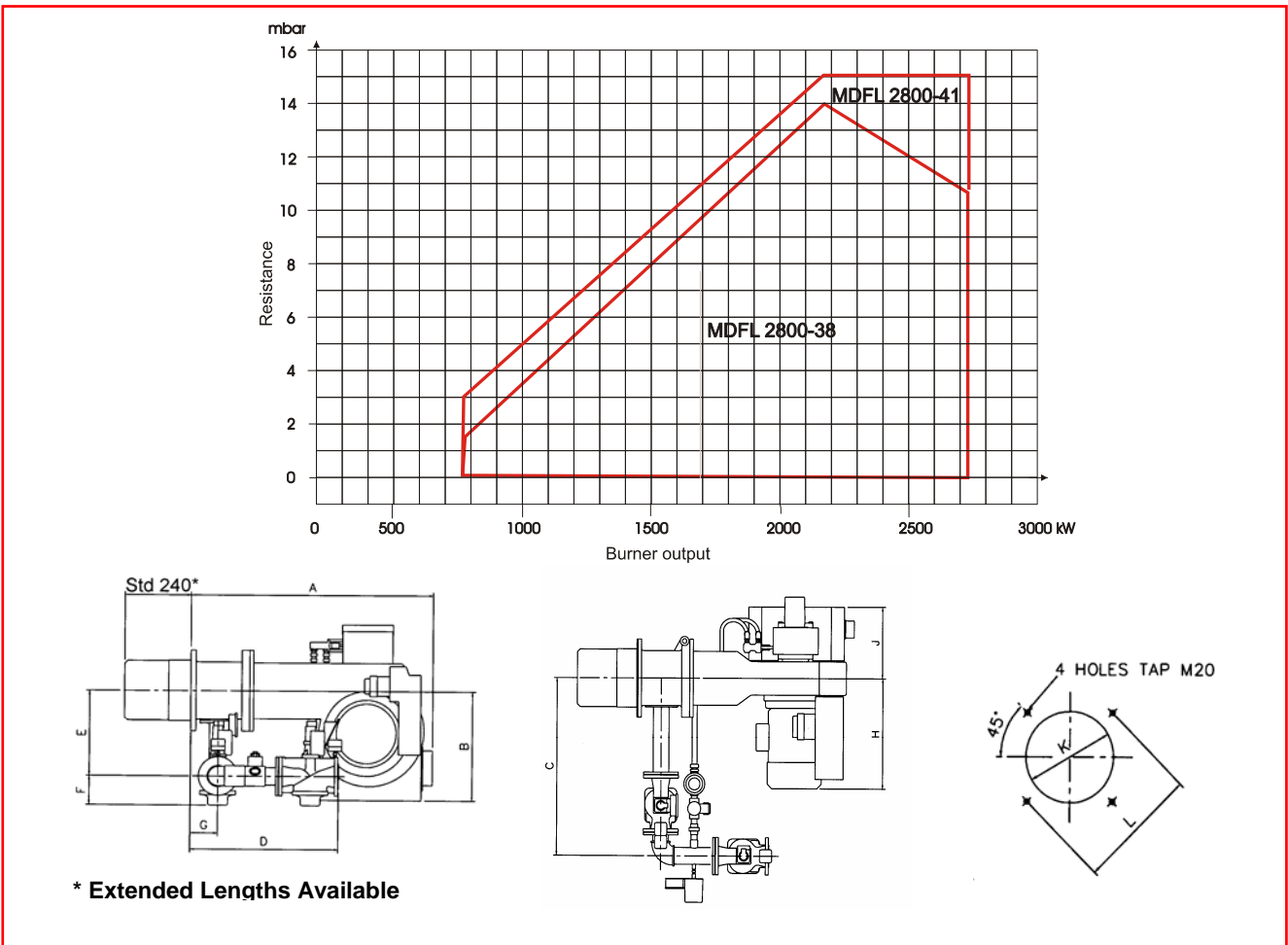

Burner	A	B	C	D	E	F	G	H	J	K	L
MDFL 2800-38	1081	475	920	735	415	165	141	500	350	280	305
MDFL 2800-41	12445	560	955	760	445	165	141	600	385	350	454



**Nu-way Limited**  
P O Box 1, Vines Lane  
Droitwich  
Worcestershire  
WR9 8NA

tel: +44 (0) 1905 794331  
fax: +44 (0) 1905 794017

email: info@nu-way.co.uk  
web: www.nu-way.co.uk