

# MDFL 760 / 1070 DUAL FUEL BURNER

280 - 1070 kW



- Designed and approved in accordance with the European Standard EN 267 and EN 676
- 2 stage or modulating (Gas – modulating / Oil – 2 stage) operation
- Plug-in contact facilitates the installation
- Available for natural gas, LPG, town gas, biogas
- Light oil
- Hinged flange
- All kW ratings are in nett CV

**NU-WAY**

Type		MDFL 760	MDFL 1070
Capacity	kW	280-760	414-1070
Motor	V/Hz	400 / 50	400 / 50
	kW/A (Fuse) + Control fuse	1.1 / 3 x 16 + 1 x 10	2.2 / 3 x 16 + 1 x 10
Start/Run Current	Amps	6.5 / 3.6	8.0 / 4.6
Control unit		MPA 22	MPA 22
Flame monitoring		UV	UV
Air damper motor		•	•
Gross weight	kg		
Volume	m <sup>3</sup>		

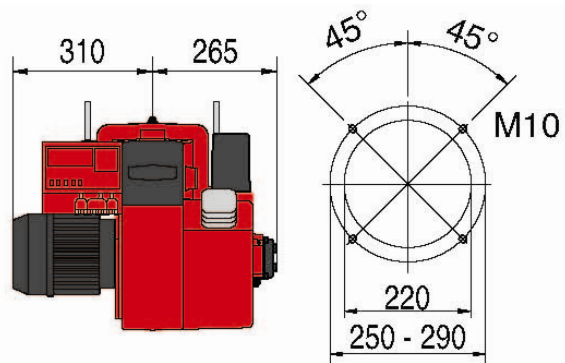
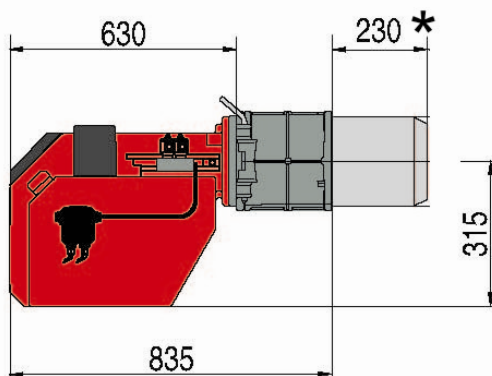
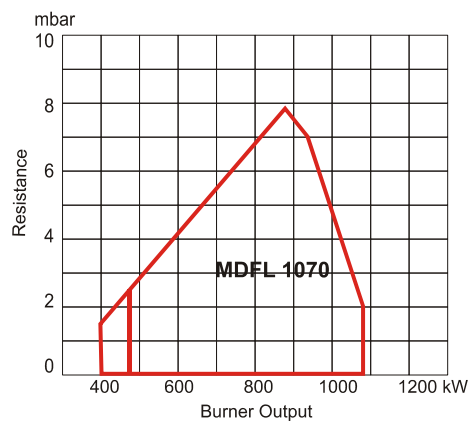
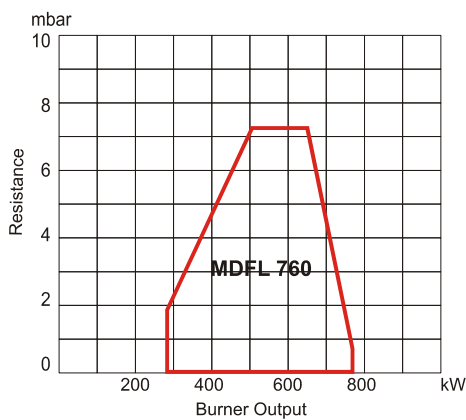

\* Extended Lengths Available

**NU-WAY**

**Nu-way Limited**  
P O Box 1, Vines Lane  
Droitwich  
Worcestershire  
WR9 8NA

tel: +44 (0) 1905 794331  
fax: +44 (0) 1905 794017

email: info@nu-way.co.uk  
web: www.nu-way.co.uk