

MGN 1550/2000 LN GAS BURNER

420-2000 kW

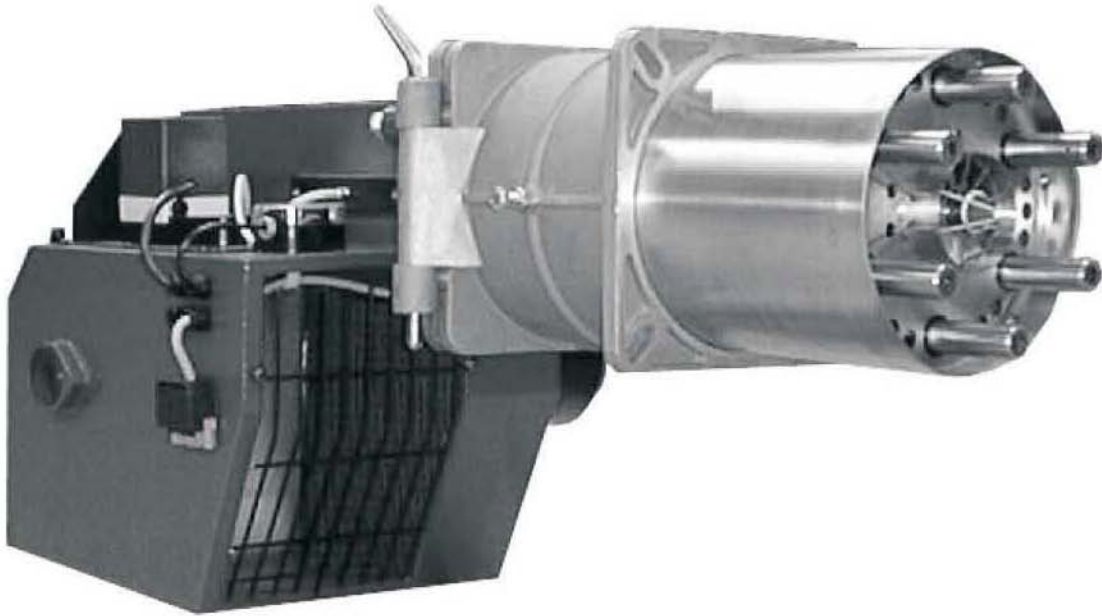

- Energy saving and compatible with environmental requirements
- Quiet in operation and designed for easy maintenance
- Designed and approved in accordance with the European Standard EN 676
- Plug-in contact facilitates the installation
- Hinged flange
- Designed for two-stage or modulating operation
- Available for natural gas
- All kW ratings are in nett CV

NU-WAY

Type		MGN 1550	MGN 2000
Capacity	kW	420-1550	700-2000
Motor	V/Hz	400 / 50	400 / 50
	kW/A (Fuse) + Control fuse	4.0 / 3 x 20 + 1 x 10	4.5 / 3 x 20 + 1 x 10
Start/Run Current	Amps	14.5 / 10.2	16.5 / 11.4
Control box		Landis	Landis
Flame monitoring		UV	UV
Operation mode		2-stage / Modulating	
Gross weight	kg	115	120

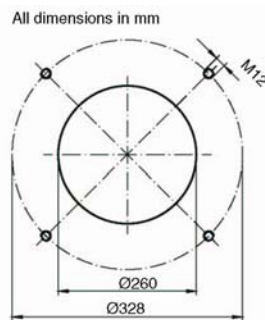
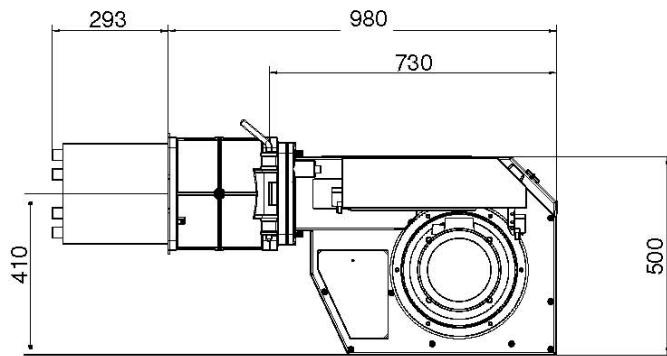
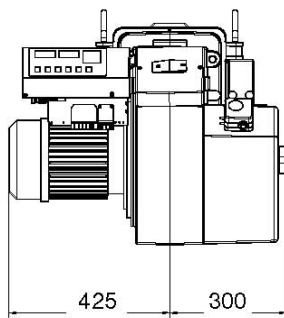
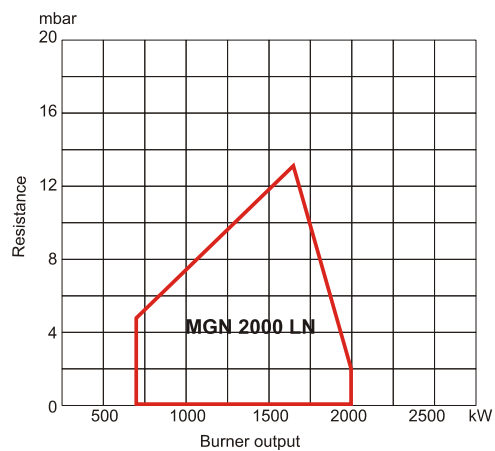
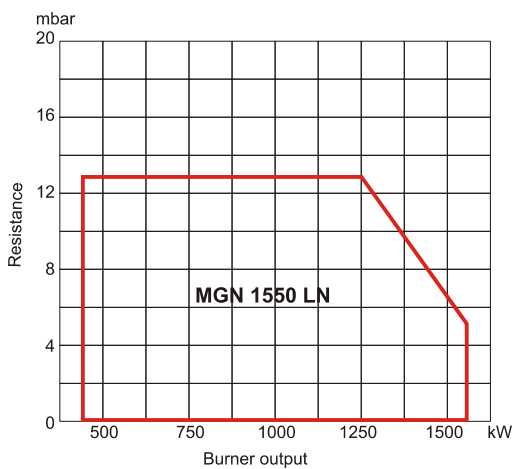

Extended Lengths Available

NU-WAY

Nu-way Limited
P O Box 1, Vines Lane
Droitwich
Worcestershire
WR9 8NA

tel: +44 (0) 1905 794331
fax: +44 (0) 1905 794017

email: info@nu-way.co.uk
web: www.nu-way.co.uk