

# MGN 190 / 320

## GAS BURNER

60 - 318 kW



- Energy saving and compatible with environmental requirements
- Quiet in operation and designed for easy maintenance
- Designed and approved in accordance with the European Standard EN 676
- Plug-in contact facilitates the installation
- Hinged flange
- Designed for 1 stage, two-stage or modulating operation
- Available for natural gas, LPG, town gas, biogas
- All kW ratings in nett CV

**NU-WAY**

Type		MGN 190	MGN 320
Capacity	kW	60-190	60-318
Motor	V/Hz	230 / 50	230 / 50
	W/A (Fuse)	180 / 10	250 / 10
Start / Run Current	Amps	5 / 2.3	8.7 / 2.2
Control box		Landis & Staefa	Landis & Staefa
Flame monitoring		Ionisation	Ionisation
Air damper motor		•	•
Operation mode		1 stage, 2 stage or Modulating	
Gross weight	kg	27	29
Volume	m <sup>3</sup>	0.13	0.15

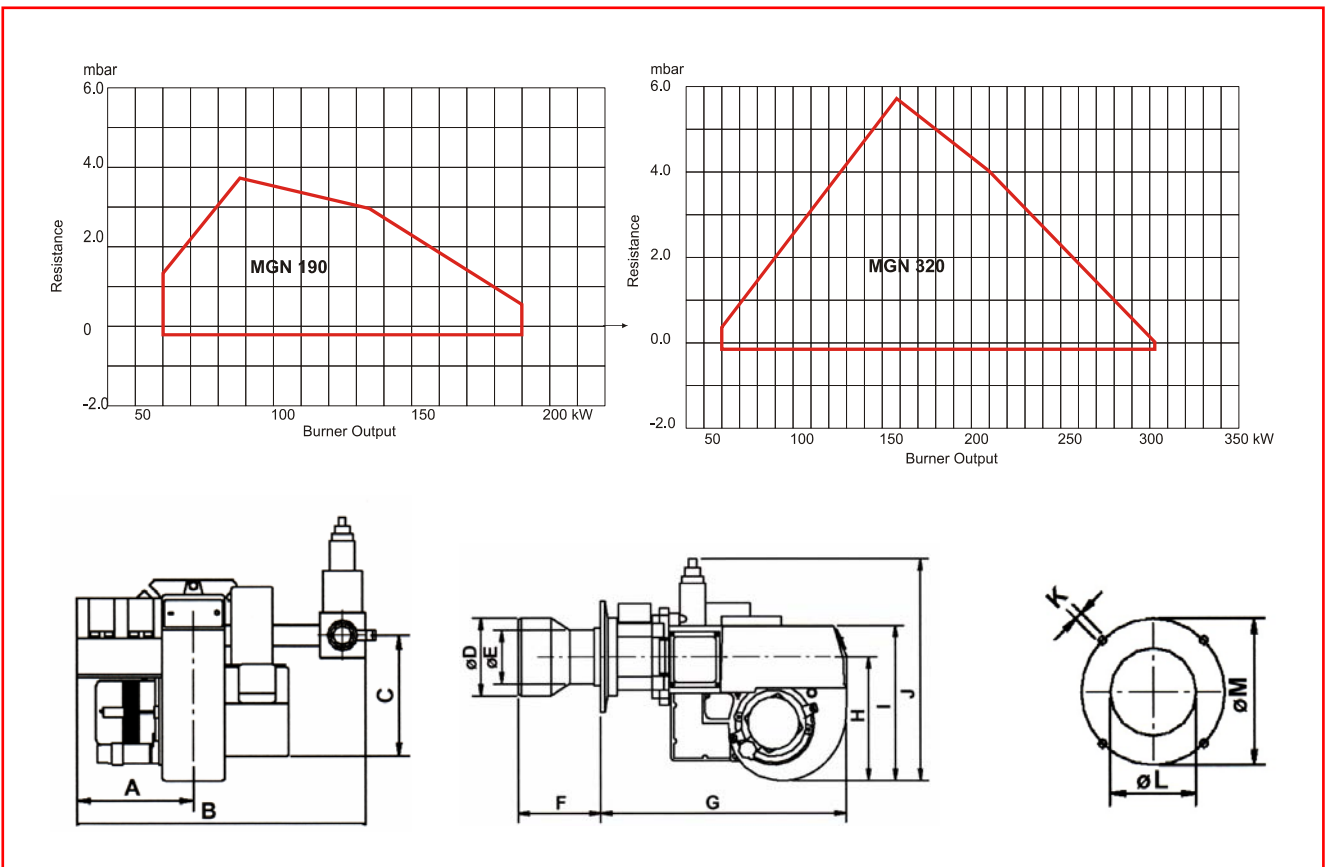

Burner	A	B	C	øD	øE	F*	G	H	I	J	K	øL	øM
MGN 190 S1L	175	460	115	120	89	125	472	220	275	380	M10	120	175-240
MGN 190 T1L	182	470	115	120	89	125	472	220	275	475	M10	120	175-240
MGN 320 S1L	195	506	222	140	100	155	510	250	304	410	M10	140	175-240
MGN 320 T1L	195	506	222	140	100	155	510	250	304	505	M10	140	175-240

\* Extended Lengths Available

**NU-WAY**

**Nu-way Limited**  
P O Box 1, Vines Lane  
Droitwich  
Worcestershire  
WR9 8NA

tel: +44 (0) 1905 794331

fax: +44 (0) 1905 794017

email: info@nu-way.co.uk

web: www.nu-way.co.uk

Issue 2 05/08