

# MGN 420 / 530-LN GAS BURNER

95 - 530 kW

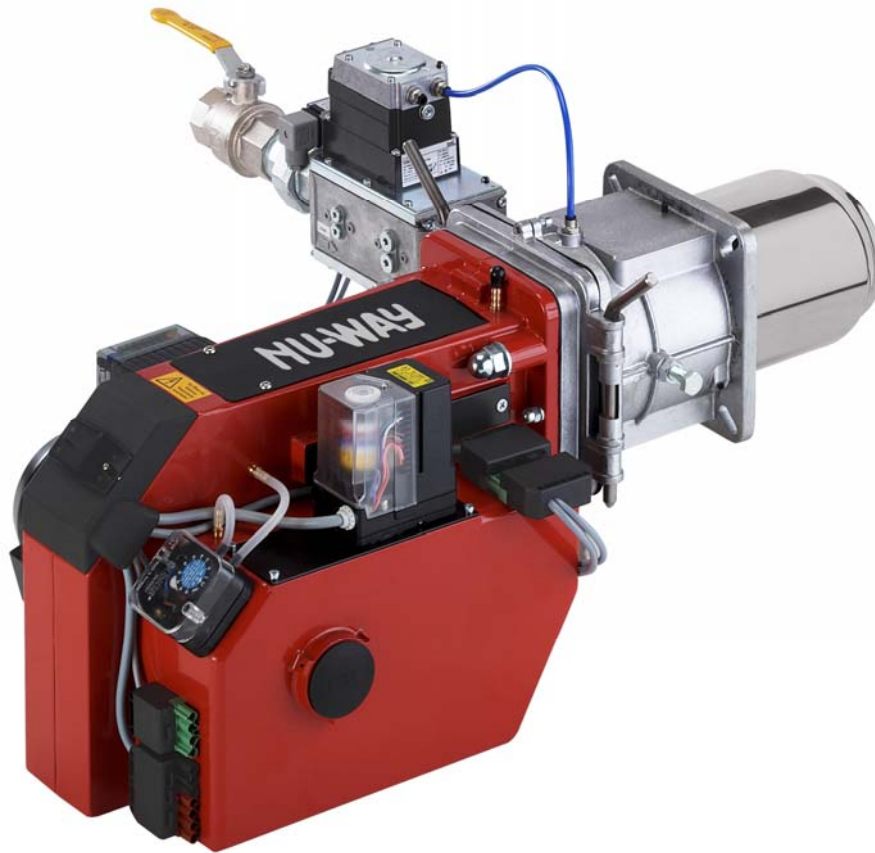

- Energy saving and compatible with environmental requirements
- Quiet in operation and designed for easy maintenance
- Designed and approved in accordance with the European Standard EN 676
- Plug-in contact facilitates the installation
- Hinged flange
- Designed for 2 stage or modulating operation
- Available for natural gas, LPG, town gas, biogas
- Low NOx as standard < 80 mg/kWh
- All kW ratings are in nett CV

**NU-WAY**

Type		MGN 420 LN	MGN 530 LN
Capacity	kW	95-420	125-530
Motor	V/Hz	230 / 50	230 / 50
	W/A (Fuse)	370 / 10	750 / 16
Start/Run Current	Amps	4.0 / 2.3	6.5 / 3.5
Control box		DMG 972 / MPA 22	DMG 972 / MPA 22
Flame monitoring		Ionisation	Ionisation
Operation mode		2 stage or modulating	
Gross weight	kg	45	48
Noise emission	dBA	≤ 78	

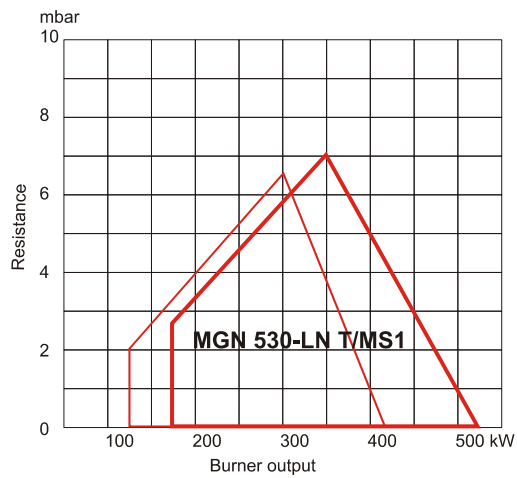
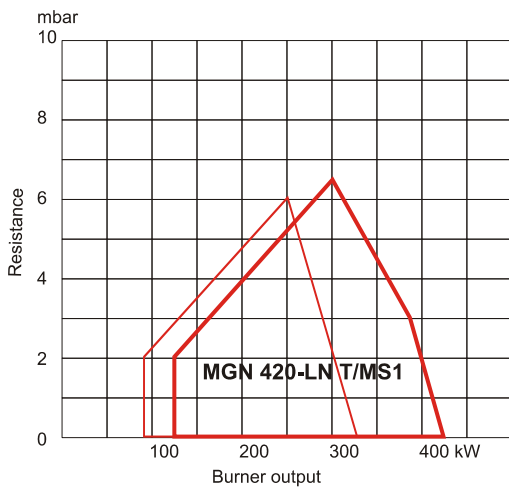

— Burner head "closed"    - - - Burner head "open"

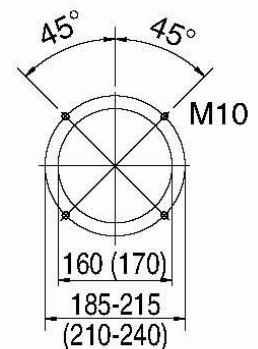
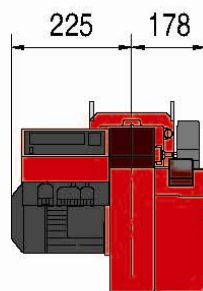
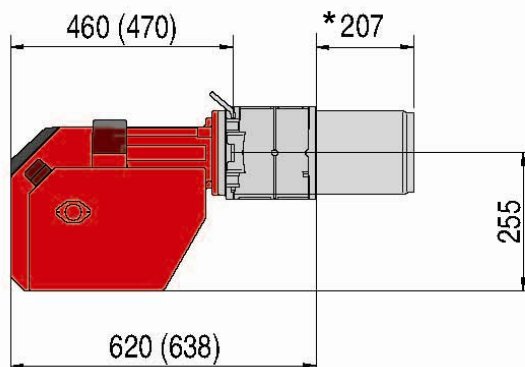

MGN 530 dimensions in brackets

\*Extended lengths Available

## PLASMA ENERGY CO.,LTD.

98/13 MOO1 NAKORNIN RD. T.BANGKUWEANG  
A.BANGKRUAI.NONTHABURI 11130 (THAILAND)

Tel: (662) 449-4900 (Auto)

FAX: (662) 496-2247

e-mail :info@plasma-energy.co.th

website : http://www.plasma-energy.co.th